



FACTORY DIRECT
— FLOORING —

Engineered
Herringbone
wood Flooring
**Installation
& Care Guide**



IMPORTANT NOTES ABOUT YOUR FLOORING. READ BEFORE INSTALLING

Care Guide

Acclimatization and Storage

Your new flooring has to be acclimatized before installation, Engineered for a minimum of 72hrs and Solid wood for a minimum of 120hrs. The flooring must remain in its packaging stored horizontal in the room which it is to be installed into. Please Note the room must be dry and have a constant relative humidity between 45 - 60% as this will affect your behaviour of your floor.

Subfloor

It is of the utmost importance that the subfloor is dry, clean, solid and flat. You can find appropriate electronic moisture meters in DIY stores, the subfloor must be flat and the flatness tolerances must be observed. The installer must always and in particular with renovation work check the current status of the subfloor, if it does not meet the requirements stated here extra work will need to be carried out to level the subfloor out, to determine the flatness of your floor apply these tolerances over 1m length the floor must not be more than 3mm difference and over 2m that rises to 4mm.

Underfloor Heating

We can recommend water based underfloor heating systems be used with a suitable engineered flooring in conjunction with a suitable underlay, a temperature not exceeding 27°C and an average running of 20°C. The heating must be turned off 48hrs prior to installation and once the flooring has been installed turned on with an increase in working temperature of 5°C per day until normal operating temperature has been reached. Water Based heating pipes are to be fitted a minimum of 30mm below the subfloor.

Tools

Having the correct tools and equipment and understanding of how to use them safely is key to a successful installation, in conjunction with some standard hand tools Hammer, Hand Saw, Square, tape measure, screw driver you may wish to use power tools such as a chop saw, jigsaw or cordless screwdriver to speed you along, paying attention when cutting with power tools to observe the blade cutting direction and place the plank accordingly to prevent breakout on the finished surface.

Expansion

Depending on the climate conditions your flooring **will** expand or contract, it therefore needs to be kept a suitable distance away from any fixed structures such as walls, supports, door frames, radiator pipes etc, this is called the expansion gap.

This gap should be a minimum of 10mm when using solid or engineered floors a gap of 8mm can be allowed on Laminate in smaller areas on each edge of the floor, larger areas the gap will need to be increased. As a guide each linear meter of flooring fitted requires a 2mm gap either side of the floor, e.g. a 6m run will require an expansion gap of 12mm each side of the floor. Larger areas such as angular areas or installations that cover more than one room will require additional clearance, these gaps can be hidden by using expansion profiles or a scotia bead, for areas over 6m x 10m please call for further assistance.

PLEASE NOTE

All flooring will CHIP, DENT and SCRATCH unless care is taken to PROTECT it, FELT PADS should be used on all moveable furniture. Matting at room entrances will greatly reduce grit and dirt from being transferred onto your flooring.

Liability for the installation remains with the installer following the fitting instructions and guides supplied and ensuring that the product and area are both suitable to be installed.

Prevent the flooring from coming into contact with a large amount of water, or from being submerged as the click connection is not waterproof.

Conservatories and rooms with excessive light should be avoided unless protection screens are used, this can be glass protection or blinds.

Always inspect materials for faults or damage as no claims on surface defects can be accepted after installation.



Engineered Herringbone Installation Guide



1. Each pack of Herringbone Flooring consists of 60 individual planks 30 left hand and 30 right hand planks, Laid side by side the right hand plank is a mirror image of the left.



2. Before you begin the installation, we recommend that you sort the planks into left and right hand piles a few minutes at the start can enhance the speed of your project later on.



3. A plank of each type will be required to create the classic Herringbone Pattern. The following page will go into detail of how to set up your flooring and begin your installation



4. An A & B plank will be required to form a joint, as with any other installations involving real wood try to work out of several packs to give an even blend of colour, shade, grain and characteristics.

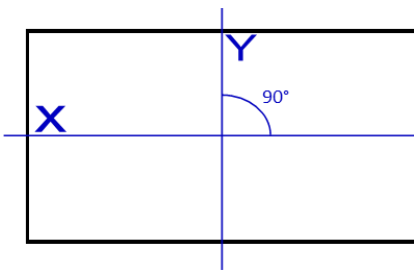

5. A herringbone design should typically be started from a central axis, using a chalk line or straight edge to mark the centre of your room create the 'x' line, then a second line needs to intersect this line at 90° to create the 'y' line. Setting this axis up is crucial and its good practice to check all angles and measurements are correct at this stage before any planks are laid.

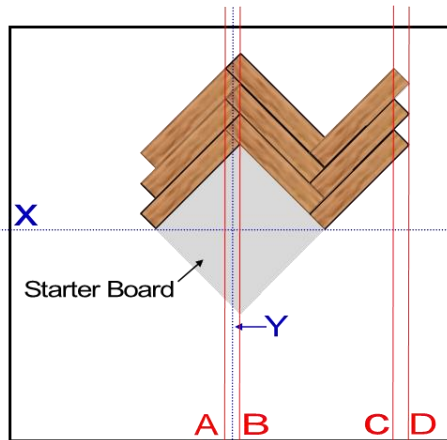

6. From the 'Y' line measure out 27mm each side and mark the floor off with lines 'A' and 'B' these will serve as guide lines as the 'Y' line runs through the centre point of the two planks once they have been joined. From plywood create a starter board, this will need to be 350 x 350mm the same as the plank length and has to be square. Lay the starter board so its top and bottom corners are in line with line 'B' and temporarily fix it to the floor. Its recommended to dry lay 3 rows (the method to join the boards is covered in the next paragraph) to determine the distance to line 'C' and 'D' repeat this to the left of the starter board to give further guide lines, these should all be parallel to the 'Y' line.

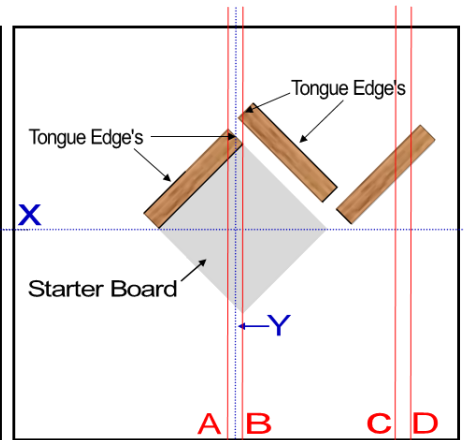

7. Once your happy with the pattern set up remove the planks and the adhesive can be spread out from the edges of the starter board. Place the first board to the left hand side of the starter board with the grooved edge against it and the tongue side and end facing out towards the room, with the top of the plank running through line 'A' and the bottom of the plank running through line 'B' The right hand side board again with the groove side to the starter board and the tongue side and end facing out to the room can be set and locked into the first plank, make sure that the tongue end of the right plank lines up with the tongue side of the left plank. Being aware of the guide lines at all times the installation can be built up in this manner, the starter can be removed further into the installation in order to complete.



Aftercare

How to Care for Your Floor

1. Remove all loose dirt and debris from the flooring by using a vacuum cleaner, broom, dust pan and brush or electro static wipes.

2. Lacquered Floors. Keeping your lacquered real wood floor is very easy, for day to day cleaning the use of a fine soft broom or vacuum cleaner with an attachment will keep most loose dirt and grit off the surface if necessary clean with a well rung out damp cloth or mop, always wipe off any spilled liquids as soon as possible, special cleaners and emulsions are available for more intense cleaning of lacquered floors but always follow the instructions and the individual manufactures guide lines. Mats placed at the entrance points to your floor will also help reduce the amount of dirt, grit and dampness form being brought onto the floor, felt floor protectors when attached to chair or table legs or any other easily moved furniture will greatly reduce the chance of damage to your floor. In excessive cases of wear Lacquered floors can be stripped sanded and re finished.

3. Oiled Floors. Regular cleaning of your oiled floor will ensure easier maintenance as a whole and increase its resistance to wear, for a day to day routine the use of a fine soft broom or vacuum cleaner with an attachment will keep most loose dirt and grit off the surface if necessary clean with a well rung out damp cloth or mop for maintenance of oiled floors add the recommended amount of cleaning agent for oiled floors this will create a protective film on the surface which will increase the resistance to wear on the floor follow the guide lines in the use of cleaning products giving enough time to allow the floor to dry before using again. Mats placed at the entrance points to your floor will also help reduce the amount of dirt, grit and dampness form being brought onto the floor, felt floor protectors when attached to chair or table legs or any other easily moved furniture will greatly reduce the chance of damage to your floor. Single planks can be re oiled as required it is recommended that in a residential location the complete floor is re oiled once a year commercial locations dependant on use may require more.

HELPFUL TIPS

Avoid dragging or sliding heavy items of furniture, carousels and point of sale across the floor.

Spending a small amount of time looking after your new Engineered floor will ensure that it continues to look at its best and provide you with many years of carefree use without the need of costly maintenance and repairs.

Never use abrasive cleaners or scourers

Never Use a wet mop or large amounts of water during cleaning

Do use mats in high traffic areas and at entrances to your wood floor

Do use drip trays underneath pot plants to protect your wood floor

Do remove any spills or excessive liquids as soon as they occur

Minor damages can be repaired with touch in kits to suit the colour of the floor

